

# TCR50-2 PRESENTATION



## TCR50-2 FEATURES

### STANDARD EQUIPMENT

- Cab (ROPS / FOPS Level II)
- Deluxe Suspension Seat w/ Head Rest
- 180 degree Swivel Skip
- Fuel Transfer Pump
- 5.7 inch LCD Cluster
- Skip End View Camera
- Travel Alarm
- TFM (Takeuchi Fleet Management; GPS)

### OPTIONAL EQUIPMENT

- Air Conditioner
- LED Package 1 (2 x Body + 2 x Cab Front)
- LED Package 2 (2 x Body + 2 x Cab Front + 1 x Cab Rear)
- TSS (Takeuchi Security System; Immobilizer)



# INTERIOR

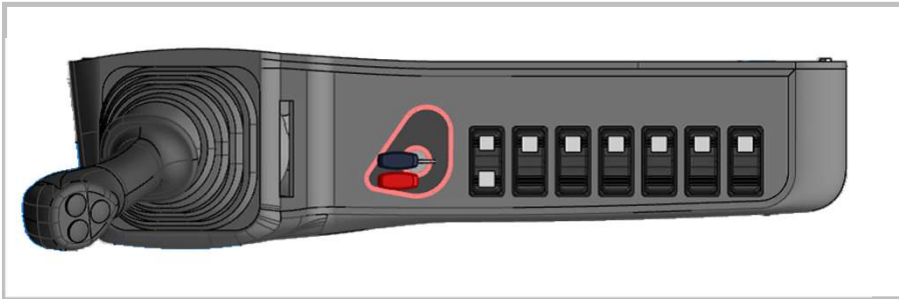

**SEALED LOCKER SWITCHES  
& HYDRAULIC JOYSTICK CONTROLS**

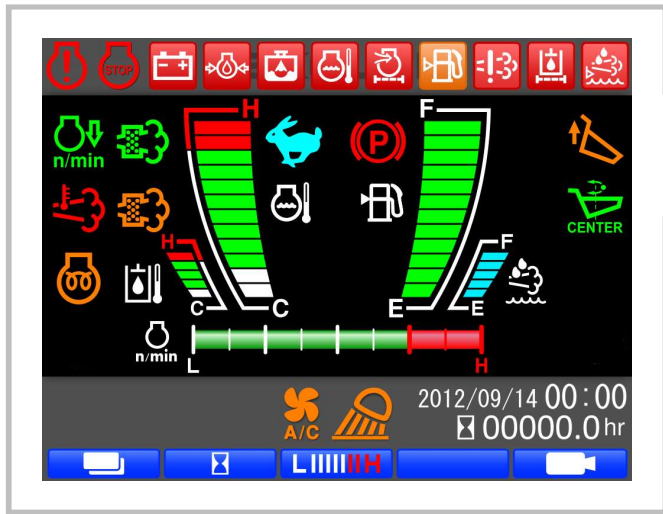

**5.7 INCH LCD CLUSTER**

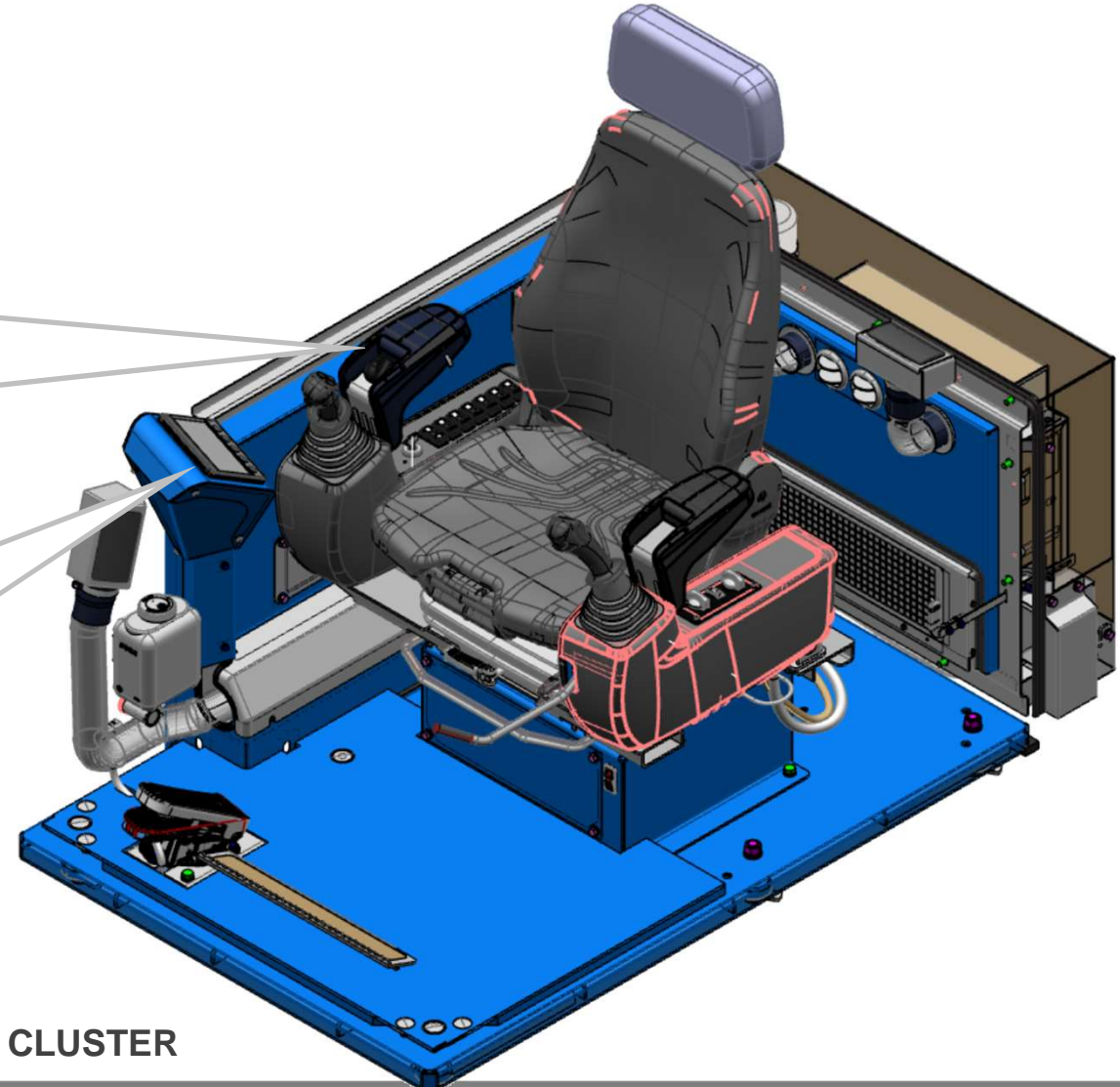

# SPECIFICATIONS

		Takeuchi	
		TCR50-2	Old TCR50
<b>Operating Performance</b>			
Operating Weight	kg	6550	6410
Dump Body Capacity - Heaped	m <sup>3</sup>	2.055	2.055
- Struck	m <sup>3</sup>	1.15	1.15
Max. Loading Weight	kg	3700	3700
Max. Travel speed	km/h	9.5	9.2
Gradeability	degree	30	30
Ground pressure - with Dump Body Full	kPa	42.1	41.5
- with Dump Body Empty	kPa	26.6	26.3
Travel Traction Force	kN	36.1 x 2	36.1 x 2
<b>Engine</b>			
Model		Yanmar 4TNV94FHT-NTBC	Yanmar 4TNV94CHT-NTBC
Emission Level		EU Stage V	EU Stage IIIB
Rated Output (ISO14396)	kW / min-1	88.4 / 2500	88.4 / 2500
Maximum Torque	Nm / min-1	410 / 1700	410 / 1700
After Treatment		DPF + SCR	DPF
Alternator	V-kW	12-0.96	12-0.96
Battery	V-A· H	12-72	12-72

## MACHINE DIMENSIONS

	Takeuchi	
	TCR50-2	Old TCR50
A	2725 mm	2725 mm
B	1040 mm	1040 mm
C	4660 mm	4660 mm
D	2500 mm	2500 mm
E	3145 mm	3145 mm
F	1330 mm	1330 mm
G	1715 mm	1715 mm
H	2200 mm	2200 mm
J	450 mm	450 mm
K	435 mm	435 mm
L	990 mm	980 mm
M	2615 mm	2615 mm
N	1795 mm	1795 mm
P	385 mm	385 mm
Q	750mm	750 mm

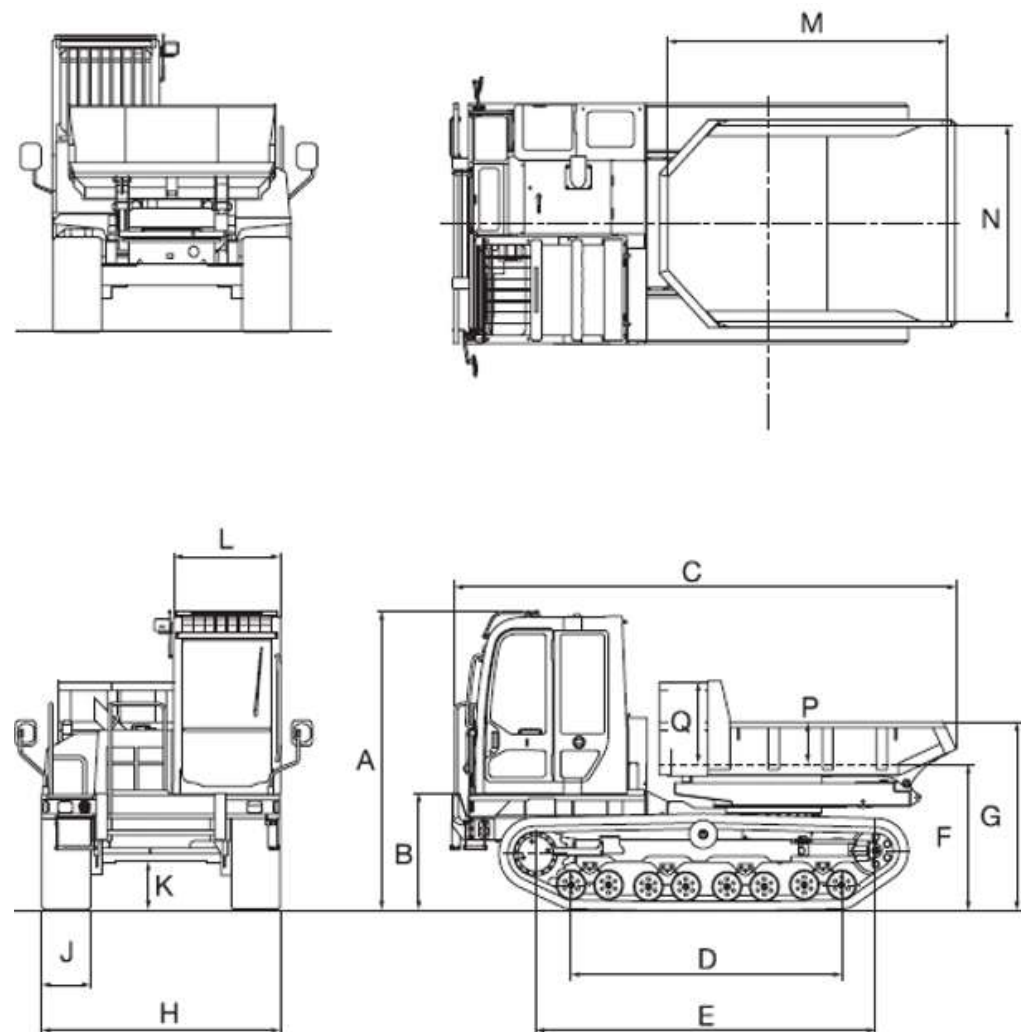

## WORKING DIMENSIONS

	Takeuchi	
	TCR50-2	Old TCR50
A	4680 mm	4680 mm
B	885 mm	885 mm
C	3610 mm	3610 mm
D	1005 mm	1005 mm
E	1730 mm	1730 mm
F	2735 mm	2735 mm
G	90°	90°
H	90°	90°
J	65°	65°

